

Register your product and get support at
www.philips.com/welcome

AZ1837



EN User manual

PHILIPS

Contents

1	Important	4
	Notice	5
	Safety	4
	Trademark notice	7

2	Your CD Soundmachine	8
	Introduction	8
	Overview of the main unit	9
	What's in the box	8

3	Get started	12
	Connect AC power	13
	Install batteries	12

4	Use your CD Soundmachine	14
	Find a passage within a track	15
	Listen to an external device	16
	Listen to radio	17
	Play a CD	14
	Play from USB devices	14
	Program play sequence	16
	Select an album	15
	Select a track	15
	Select play modes	15

5	Product information	18
	USB playability information	18

6	Troubleshooting	20
	Troubleshooting	20

1 Important

Safety

Know these safety symbols



This 'bolt of lightning' indicates uninsulated material within your unit may cause an electrical shock. For the safety of everyone in your household, please do not remove product covering.

The 'exclamation mark' calls attention to features for which you should read the enclosed literature closely to prevent operating and maintenance problems.

WARNING: To reduce the risk of fire or electric shock, this apparatus should not be exposed to rain or moisture and objects filled with liquids, such as vases, should not be placed on this apparatus.

CAUTION: To prevent electric shock, fully insert the plug. (For regions with polarized plugs: To prevent electric shock, match wide blade to wide slot.)

- ① Read these instructions.
- ② Keep these instructions.
- ③ Heed all warnings.
- ④ Follow all instructions.
- ⑤ Do not use this apparatus near water.
- ⑥ Clean only with dry cloth.
- ⑦ Do not block any ventilation openings. Install in accordance with the manufacturer's instructions.
- ⑧ Do not install near any heat sources such as radiators, heat registers, stoves, or other apparatus (including amplifiers) that produce heat.
- ⑨ Protect the power cord from being walked on or pinched, particularly at plugs, convenience receptacles, and the point where they exit from the apparatus.
- ⑩ Only use attachments/accessories specified by the manufacturer.

- ⑪ Unplug this apparatus during lightning storms or when unused for long periods of time.
- ⑫ Refer all servicing to qualified service personnel. Servicing is required when the apparatus has been damaged in any way, such as power-supply cord or plug is damaged, liquid has been spilled or objects have fallen into the apparatus, the apparatus has been exposed to rain or moisture, does not operate normally, or has been dropped.
- ⑬ Battery usage **CAUTION** – To prevent battery leakage which may result in **bodily injury, property damage, or damage to the unit:**
 - Install all batteries correctly, + and - as marked on the unit.
 - Do not mix batteries (old and new or carbon and alkaline, etc.).
 - Remove batteries when the unit is not used for a long time.
- ⑭ Apparatus shall not be exposed to dripping or splashing.
- ⑮ Do not place any sources of danger on the apparatus (e.g. liquid filled objects, lighted candles).
- ⑯ Where the **MAINS** plug or an appliance coupler is used as the disconnect device, the disconnect device shall remain readily operable.



Warning

- Never remove the casing of this apparatus.
- Never lubricate any part of this apparatus.
- Never place this apparatus on other electrical equipment.
- Keep this apparatus away from direct sunlight, naked flames or heat.
- Never look into the laser beam inside this apparatus.
- Ensure that you always have easy access to the power cord, plug or adaptor to disconnect this apparatus from the power.



Caution

- Use of controls or adjustments or performance of procedures other than herein may result in hazardous radiation exposure or other unsafe operation.

Notice

Any changes or modifications made to this device that are not expressly approved by Philips Consumer Lifestyle may void the user's authority to operate the equipment.



This product complies with the radio interference requirements of the European Community.



Your product is designed and manufactured with high quality materials and components, which can be recycled and reused.



When this crossed-out wheeled bin symbol is attached to a product it means that the product is covered by the European Directive 2002/96/EC.

Please inform yourself about the local separate collection system for electrical and electronic products.

Please act according to your local rules and do not dispose of your old products with your normal household waste. Correct disposal of your old product helps to prevent potential negative consequences for the environment and human health.



Your product contains batteries covered by the European Directive 2006/66/EC, which cannot be disposed with normal household waste. Please inform yourself about the local rules on separate collection of batteries because correct disposal helps to prevent negative consequences for the environmental and human health.

Environmental information

All unnecessary packaging has been omitted. We have tried to make the packaging easy to separate into three materials: cardboard (box), polystyrene foam (buffer) and polyethylene (bags, protective foam sheet.)

Your system consists of materials which can be recycled and reused if disassembled by a specialized company. Please observe the local regulations regarding the disposal of packaging materials, exhausted batteries and old equipment.

Recording and playback of material might require consent. See Copyright Act 1956 and The Performer's Protection Acts 1958 to 1972.



The making of unauthorized copies of copy-protected material, including computer programs, files, broadcasts and sound recordings, may be an infringement of copyrights and constitute a criminal offence. This equipment should not be used for such purposes.

Trademark notice



Windows Media and the Windows logo are trademarks, or registered trademarks of Microsoft Corporation in the United States and/or other countries.

This apparatus includes this label:

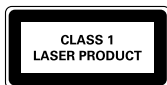

Class II equipment symbol:



This symbol indicates that this product has a double insulation system.



Note

- The type plate is located on the bottom of the apparatus.

2 Your CD Soundmachine

Congratulations on your purchase, and welcome to Philips! To fully benefit from the support that Philips offers, register your product at www.philips.com/welcome.

Introduction

With the CD Soundmachine, you can:

- play CDs, MP3/wma discs
 - play mp3/wma files on USB devices
 - listen to FM/MW radio
 - program the play sequence of tracks.
-





What's in the box

Check and identify the contents of the package:

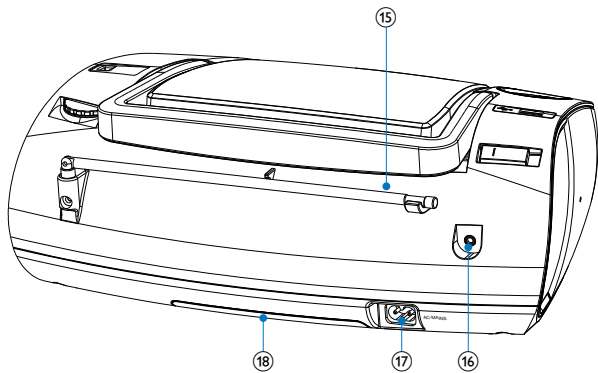
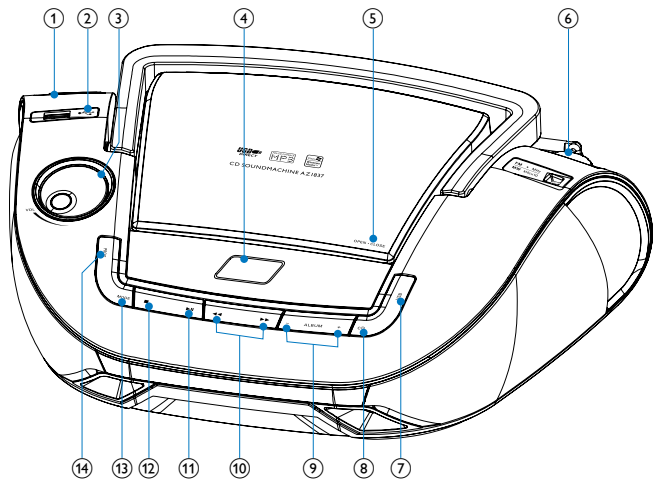
- Main unit
- AC power cord
- MP3 link cord
- User Manual

Overview of the main unit



- ① **Source selector: CD/USB,FM, MW, OFF.**
 - Select CD/USB, FM, MW(AM) source or turn off the unit
- ② 
 - USB socket.
- ③ **VOL+/-**
 - Adjust volume level
- ④ **Display panel**
 - Show current status.
- ⑤ **OPEN/CLOSE**
 - Press to open or close the disc compartment.
- ⑥ **TUNING+/-**
 - Tune to radio stations
- ⑦ **USB**
 - Select USB device source.
- ⑧ **CD**
 - Select CD source.
- ⑨ **- ALBUM +**
 - For MP3-CDs: Skip to the next/previous album in an MP3-CD
- ⑩ 
 - Select the previous/next track
 - Search backward/forward
- ⑪ 
 - Start or pause play
- ⑫ 
 - Stop play.
 - Erase a program
- ⑬ **MODE**
 - Select a play mode: REPEAT or SHUFFLE
- ⑭ **PROG**
 - For MP3-CDs: Program tracks and browse the program
- ⑮ **Telescopic antenna**
 - Adjust FM reception
- ⑯ **MP3 LINK**
 - Socket for connecting an external device

- ⑰ **AC MAINS**
 - Jack for the supplied AC power cord
- ⑱ **Battery compartment door**

3 Get started



Caution

- Use of controls or adjustments or performance of procedures other than herein may result in hazardous radiation exposure or other unsafe operation.

Always follow the instructions in this chapter in sequence.

If you contact Philips, you will be asked for the model and serial number of this apparatus. The model number and serial number are on the bottom of the apparatus.

Write the numbers here:

Model No. _____

Serial No. _____

Install batteries



Note

- You can use both batteries and AC power as power supply of this apparatus.
- Batteries are not supplied with the accessories.

- 1 Open the battery compartment.
- 2 Insert 6 x 1.5V R14/UM-2/C-cell batteries with correct polarity (+/-) as indicated.
- 3 Close the battery compartment.

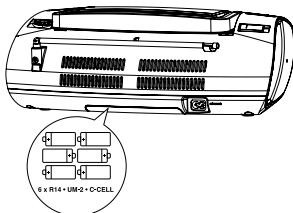

Connect AC power



Caution

- Risk of product damage! Ensure that the power supply voltage corresponds to the voltage printed on the back or the underside of the unit.



Warning

- Risk of electric shock! When you disconnect the AC power, always pull the plug from the socket. Never pull the cord.



Note

- Install the apparatus near the power supply socket and where the AC power plug can be easily reached.

- 1 Connect the power cord to the **AC~ MAINS** socket on the apparatus and to the power supply socket.



Note

- To save energy: After use, set the switch to **OFF**.

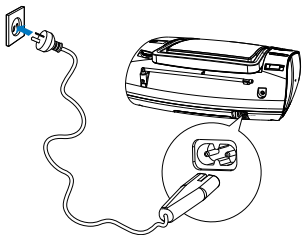

4 Use your CD Soundmachine

Play a CD



Note

- You cannot play CDs encoded with copyright protection technologies.

You can play commercially available audio CDs:

- CD-Recordables (CD-R)
- CD-Rewritables (CD-RW)
- MP3-CDs
- WMA-CDs

- 1 Switch the source selector to **CD/USB**.
- 2 Press and open the lid of the CD compartment.
- 3 Insert a CD with the printed side facing up.
- 4 Close the CD lid.
- 5 Press **CD** to select CD source.
- 6 Press **▶||** to start play.
 - ↳ **[▶]** is displayed.
 - ↳ To stop play, press **■**.
 - ↳ To pause or resume play, press **▶||**.

Play from USB devices



Note

- Ensure that the USB device contains playable audio contents for supported formats.

- 1 Insert the USB connector on the device into the  socket.

- 2 Switch the source selector to **CD/USB**.
 - 3 Press **USB** to select USB source.
 - 4 Press **- ALBUM +** to select a folder.
 - 5 Press **◀◀▶▶** to select a file.
 - 6 Press **▶||** to start play.
 - To stop play, press **■**.
 - To pause or resume play, press **▶||**.
-

Select a track

- 1 Press **◀◀▶▶** to select a track.
-

Select an album

For MP3-CDs only.

- 1 Press **- ALBUM +** to select an album.
-

Find a passage within a track

- 1 Press and hold **◀◀▶▶**.
 - ↳ The CD is played at high speed and with reduced volume.
- 2 Release **◀◀▶▶** to resume normal play.



Tip

- When search reaches the end of the last track, the CD stops.
-

Select play modes

- 1 Press **MODE** repeatedly to select a play mode:
 - **[↻]** (repeat) – repeat a track
 - **[↻ ALL]** (repeat all) - repeat an entire CD/program
 - **[🔀]** (shuffle) - play tracks randomly
 - **[🔀↻ ALL]** (shuffle repeat all) - repeat all tracks randomly.

- 2 To return to normal play, press **MODE** repeatedly until play mode icons are no longer displayed.



Tip

- Shuffle play cannot be selected when you play programmed tracks.

Program play sequence

You can program up to 20 tracks in the desired sequence.

- 1 In stop mode, press **PROG** to start to program play sequence.
 - ↳ **[PROG]** and **[P01]** are displayed.
 - ↳ For MP3-CDs: press **-ALBUM +** to select an album.
- 2 Press **◀◀▶▶** to select a track.
- 3 Press **PROG** to program the track.
 - ↳ **[PROG]** and **[P02]** are displayed.
- 4 Repeat steps 2 to 4 to select and program all tracks.
 - ↳ When all 20 tracks are stored, no more tracks can be selected and the display shows **[FUL]**.
- 5 To play program, press **▶||**.
 - In stop mode, press and hold **PROG** to browse programmed tracks.
- 6 To delete program, press **■** in stop mode.
 - ↳ **[CLr]** is displayed.

Listen to an external device

You can use this unit to play audio from an external device.

- 1 Connect the MP3 link cable to
 - the **MP3-LINK** jack (3.5 mm) on the back of this unit
 - the audio output jack of the external device.
 - ↳ This unit stops the current playback and starts to play the audio input from the external device.

Listen to radio

- 1 Switch the **FM/MW selector** to **FM** or **MW**.
- 2 Turn **TUNING+/-** until you find optimal reception.



Tip

- To improve FM reception, you can extend, incline or turn the telescopic antenna for best reception.
- To improve MW reception, turn the apparatus to face a different direction.

5 Product information



Note

- Product information is subject to change without prior notice.

Dimensions (W x H x D)	341 x 122 x 236 (mm)
Weight	1.8 kg
Power supply	AC: 230-240V~, 50 Hz DC: 6 X 1.5 V  / R14, UM2 or C cells
Power consumption	< 12 W (Active)
Power output	2 x 1 W RMS
Operating temperature range	-10 °C - 50 °C 14 °F -122 °F

USB playability information

Compatible USB devices:

- USB flash memory (USB 2.0 or USB1.1)
- USB flash players (USB 2.0 or USB1.1)
- memory cards (requires an additional card reader to work with this unit)

Supported formats:

- USB or memory file format FAT12, FAT16, FAT32 (sector size: 512 bytes)
- MP3 bit rate (data rate): 32-320 Kbps and variable bit rate
- WMA v9 or earlier
- Directory nesting up to a maximum of 8 levels
- Number of albums/ folders: maximum 99
- Number of tracks/titles: maximum 999
- ID3 tag v2.0 or later
- File name in Unicode UTF8 (maximum length: 128 bytes)

Unsupported formats:

- Empty albums: an empty album is an album that does not contain MP3/WMA files, and is not be shown in the display.
- Unsupported file formats are skipped. For example, Word documents (.doc) or MP3 files with extension .dlf are ignored and not played.
- AAC, WAV, PCM audio files
- DRM protected WMA files (.wav, .m4a, .m4p, .mp4, .aac)
- WMA files in Lossless format

6 Troubleshooting

Troubleshooting



Warning

- Never remove the casing of this apparatus.

To keep the warranty valid, never try to repair the system yourself.

If you encounter problems when using this apparatus, check the following points before requesting service. If the problem remains unsolved, go to the Philips web site (www.Philips.com/support). When you contact Philips, ensure that the apparatus is nearby and the model number and serial number are available.

No power

- Ensure that the Mains cord is connected securely.
- Ensure that there is power at the AC Mains.
- Ensure that the batteries are inserted correctly.

No sound

- Adjust the volume.
- Ensure that the track played is of a compatible format.

Display does not function properly, or No reaction to operation of any of the controls.

- Disconnect the AC power cord and then reconnect it after a few seconds.

Cannot play disc

- Ensure that the disc label is inserted with the printed side facing up.
- Wipe the disc with fibre cleaning cloth from the centre to the edge in a straight line.
- This disc may be defective. Play another disc.
- Ensure that the CD is a finalised CD/CD-R/CD-RW.
- Ensure that the laser lens is clean.
- Ensure that the CD is not encoded with copyright protection technologies.

The CD skips tracks

- Ensure that the CD is not damaged or dirty.
- Ensure that program/shuffle mode is deactivated.

USB device or SD/MMC card not supported

- The USB device or SD/MMC card is incompatible with the apparatus. Try another one.



© 2010 Koninklijke Philips Electronics N.V.

All rights reserved.

AZ1837_79_UM_V1.0

